

FABRICATION MANUAL **SCM/TCM**

You discover why ALPOLIC® Stainless Steel and Titanium composite materials (SCM and TCM) are the building materials of the future as soon as you fabricate them. Our SCM and TCM panels require slightly different tooling and processing conditions compared to our ACM products. For specific recommendations please contact your ALPOLIC Sales Representative. ALPOLIC® SCM and TCM's versatility makes them readily adaptable to many standard systems that are available from a variety of vendors, including rout & return systems, glazed-in systems and creative custom systems. In addition, you can create complex assemblies with ALPOLIC® SCM and TCM in combination with support systems attached with structural adhesives. The TCM and SCM panels are produced using the fr core technology.

For further design, detailing and fabrication guidance, please refer to the materials in this section, or go to www.alpolic-usa.com. For samples or a list of authorized ALPOLIC® fabricators, please call the ALPOLIC® Hotline toll-free at 1-800-422-7270, or e-mail us at info@alpolic.com.

VISUAL CONSISTENCY

ALPOLIC TCM/SCM have natural metal skins, Since there is no coating or surface treatment, the appearance of the panel is totally reliant on the metal used. The aging characteristics and visual appearance may vary from coil to coil due to slight differences in the metal, location or orientation of the installed panels and the local environment. As with Metallics, HLA/HPA and Anodized finishes, it is recommended that lots not be mixed on a building face and the directional arrows be aligned. Also with Titanium, the surface appearance will change with time and the environment to which the panel is exposed .

PROPERTIES

Thermal Expansion/Contraction

Thermal expansion/contraction must be considered when designing with ALPOLIC® TCM / SCM .

To calculate thermal expansion/contraction, use the following equations:

$$\text{Thermal Expansion/Contraction (inches)} = 12 \times \text{Cth} \times \Delta T(^{\circ}\text{F}) \times \text{L(feet)}$$

$$\text{TCM/SCM Cth} = \text{Coefficient of thermal expansion} (5.7 \times 10^{-6} \text{ in/f/F})$$

L = Length of ALPOLIC panel

$\Delta T = T_a - T_i$ where T_a is the actual temperature and T_i is the temperature when ALPOLIC was fabricated or installed. A positive ΔT indicates expansion and negative ΔT indicates contraction.

Fire Resistance Properties

	TCM		SCM
	4mm/157"		4mm/.157"
Surface burning ASTM E84			
Smoke developed index	0		0
Flame spread index	0		0

Physical Properties

Item	Unit	ASTM	ALPOLIC	
			4mm TCM	4mm SCM
Specific gravity			2.3	2.5
Weight 1b/ft:			1.90	2.09

Thermal conductivity	BTU/ft hr °F(apparent)	C-976	0.23	0.23
Thermal resistance	Ft:hr°F/BTU(apparent)	C-976	0.95	0.95
Deflection temperature	°F	D-648	234	243

Mechanical Properties

Item	Unit	ASTM	ALPOLIC	
			4mm TCM	4 mm SCM
Tensile strength	KSI	E-8	9.82	12.06
Yield strength	KSI	E-8	8.58	9.85
Elongation	%	E-8	11.1	12.6
Punching Shear Resistance				
Maximum load	Lb	D-732	6776	7737
Shear resistance (50mm)	KSI	D-732	8.3	9.5

Dent (Impact) Test by DuPont Method

Dent Depth (mm)			
Steel ball (kg)	Height (mm)	ALPOLIC	
		4mm TCM	4mm SCM
0.3	300	0.5	0.5
0.5	500	1.1	1.1
1.0	300	1.2	1.2
1.0	500	1.6	1.6

Production Tolerance

Width	±0.08" (2mm)
Length	±0.16" (4mm)
Thickness	±0.008" (.2mm)
Bow	Maximum 0.5% of the length and/or width
Squareness	Maximum 0.2" (5mm)

Bond Integrity

Item	Unit	ASTM	TCM	SCM
			4mm/.157"	4mm/.157"
Vertical pull	PSI	C-297	1,800	427
Drum peel	In-lb/in	D-1781-98	26.1	24.1
Nmm/mm	Nmm/mm	D-1781-98	116.2	107
Flatwise shear	PSI	C-273	1,220	949

MECHANICAL PROCESSING

Vibration Damping

As a laminated composite material, ALPOLIC® TCM / SCM can dampen vibration by either absorbing vibration energy or converting it into thermal energy.

Sound Transmission

When tested in conformity with ASTM E-413, the following sound transmission classes (STC Nos.) were established:

4mm TCM -STC 30

4mm SCM -STC 25

Wind Load Deflection

Wind load deflection depends on the thickness, aspect ratio, span and boundary condition (whether ALPOLIC® TCM / SCM is simply supported or fixed).

The aspect ratio is the ratio of the longer to the shorter dimension of a panel. Panels with the same area but different aspect ratios will have different wind load deflections. For example, a 2' x 8' panel with an aspect ratio of 4 will have a smaller wind load deflection than that of a 4' x 4' panel with an aspect ratio of 1.

For more information and calculations of wind load and deflection please refer to the download section of ALPOLIC-USA.com

For the 4 mm TCM panel:

$$E_{ap} * t_{ap}^2 = 27.7 * 10^3 \text{ lbf} * \text{in}$$

For the 4 mm SCM panel:

$$E_{ap} * t_{ap}^2 = 39.9 * 10^3 \text{ lbf} * \text{in}$$

For information on mechanical routing , drilling and processing please contact your ALPOLIC Sales Representative .

Bending

ALPOLIC® TCM/SCM should be processed on a flat surface, void of irregularities, to insure consistency in the depth of the 'U' grooving. This will insure a smooth clean edge when bent.

If available, a plate or break press should be used to bend processed ALPOLIC® TCM/SCM. When this is not possible a simple bending jig made of wood or metal is recommended.

When ALPOLIC® is processed with a 'U' groove and bent at 90°, the finished panel dimension will increase. This should be factored into the panel dimensions before final fabrication. It is advisable to do a preliminary test to insure the proper adjustment necessary.

Curving

ALPOLIC® TCM/SCM can be easily curved using any of the following processes: Press Brake, Roll Bender, Pipe Fixture.

The following are guidelines and limitations for curving ALPOLIC® panels.

Press Brake

The minimum bending radius using a press brake is shown in the following table.

The Minimum Bending Radius with a Press Brake, 90° Bending and Internal Radius

<i>Thickness of ALPOLIC</i>	<i>Traverse (width)</i>	<i>Parallel (Length)</i>
TCM 4mm	4"	4"
SCM 4 mm	5.5"	5.5"

Guidelines in bending process:

Because the metal skin surface material can be easily scratched, it is recommended that the following precautions be taken:

- To prevent scratches, a protective pad should be used on the die of the press brake.
- Pay attention to any scratches on the punch. It is recommended to use a fully polished punch.
- To prevent scratching, it is best to leave the factory applied protective film on the ALPOLIC® TCM/SCM during processing. Be sure there are no air bubbles or wrinkles before processing.
- With ALPOLIC® TCM/SCM the volume of spring back varies somewhat in relationship to the bending direction, thickness, material temperature and the radius of the required bending angle.

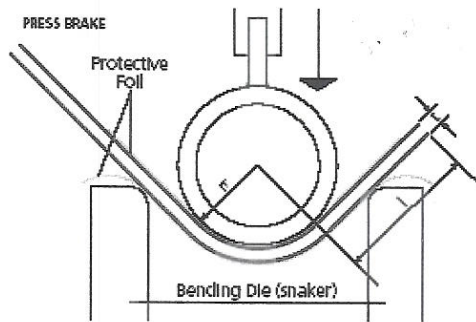

Bending with a Roller Bender:

A Roller Bender enables a larger bending radius than a press brake. The bending angle is determined by the diameter of the roll and the distance between the rolls. However a flat surface will appear at the beginning and the end of the panel. When this is not acceptable it will be necessary to cut off and remove the flat surface, in the finish fabrication process.

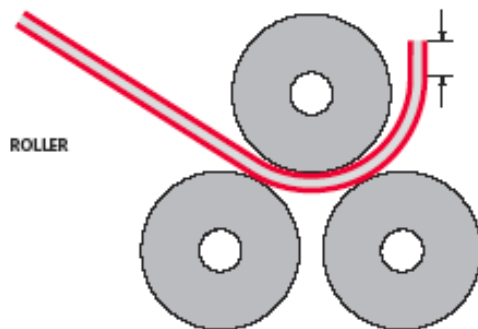

Bending with Clamped Pipe Fixture:

ALPOLIC® TCM/SCM can be bent over a pipe of the proper inside diameter that is securely clamped to a table. A hinged leaf attached to the end of the table will make bending easier. Initial bending beyond 90 may be required to compensate for any memory spring back.

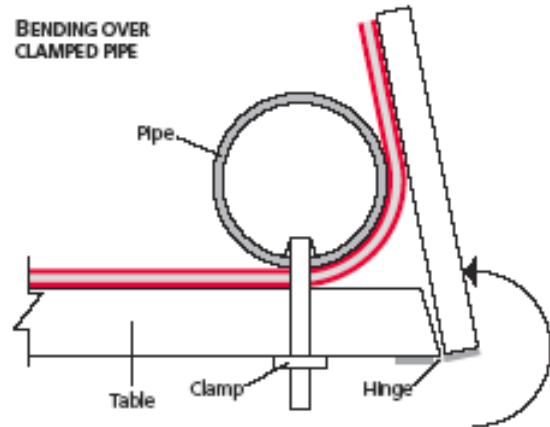

Punching

Punching

Punching with a press sometimes causes shear droop in the metal skin material. It is preferable that the clearance of punch and die be made as small as possible (thickness of panel times 5%).

In the case of a small diameter hole (under 1/6") the tool may need to be modified as shown below to ensure that the core is completely removed in the process.

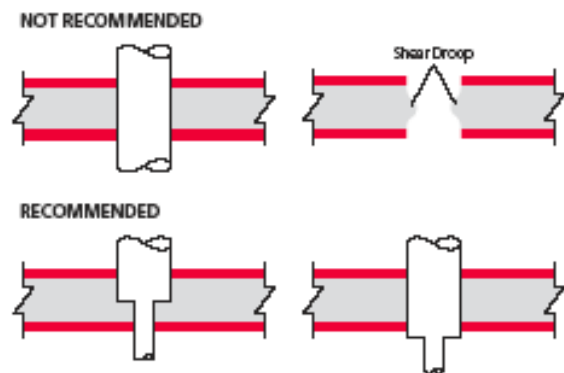

Attachment Systems

Attachment Concepts

Please reference the joint details diagrams in the download section on ALPOLIC-Northamerica.com

JOINING ADHESION

Typical methods of joining ALPOLIC® TCM/SCM are the use of threaded fasteners, rivets, adhesives and double-faced high strength tapes. Proper consideration should be given to the thermal expansion characteristics of ALPOLIC® TCM/SCM. Use the general guidelines listed below when other elements come in direct contact with the surface of ALPOLIC® TCM/SCM. When attaching dissimilar metals consideration needs to be given to the possible corrosion of joining surface due to electrolysis of dissimilar materials. If these materials must be used, make sure that a protective coating or separation exists between the two surfaces.

Threaded Fasteners

When using threaded fasteners, caution should be taken not to over tighten the fastener. The examples below show different threaded fastening methods. Stainless Steel fasteners must be used

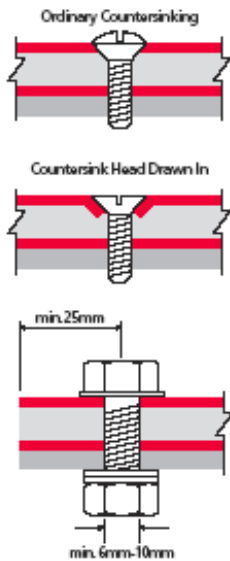

Rivets

Rivets can be used to fasten ALPOLIC® TCM/SCM panels together or to aluminum extrusion profiles. Rivets are especially suitable for fastening when vibration is likely. Stainless steel rivets must be used. Colored plastic concealment caps can be used to conceal exposed rivet heads.

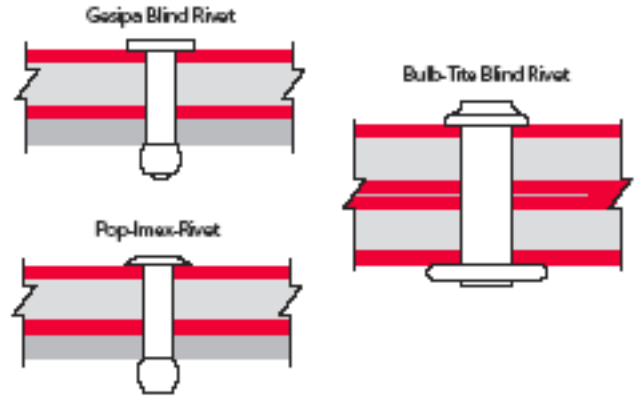

Adhesives & High Bond Tapes

When the ALPOLIC® attachment surface is flat (i.e. wall, ceiling, sign board, etc.) construction adhesive or double-faced high bond tapes can be used for installation. See the technical bulletin on ALPOLIC and VHB tapes In the download section of ALPOLIC-USA.com. See recommended adhesive supplier for more details.

APPENDICES

Masking

ALPOLIC[®] TCM/SCM comes with a factory applied protective masking film which should be removed after fabrication.

Storage

ALPOLIC[®] TCM/SCM is packed in wooden crates and can usually be stacked up to four crates high.

When storing unpacked ALPOLIC[®] TCM/SCM observe the following guidelines:

- To prevent warping or bending, place it horizontally on pallet or other stand.
- Avoid stacking ALPOLIC[®] of different sizes together, as the surface or panel can be scratched by the edges of the smaller pieces.
- Preferably, store them by size in racks.
- In storing them by leaning against the rack as shown below, lay a rubber mat underneath and lean the ALPOLIC[®] closely against the fixed back-up material.

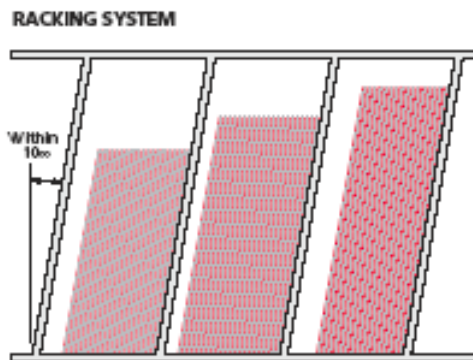

Cleaning

TCM

1. General

Titanium, the surface skin material of Titanium Composite Material (TCM), will not rust, when used for external cladding or roof no matter where the building is located. Even in areas as corrosive as the sea coast rusting is not a problem. However staining, caused by various factors, will take place on the titanium surface. Suitable cleaning method for each

staining factor is described here together with general notes for cleaning procedures.

2. Stain and suitable cleaning procedure

(1) Stain from finger prints:

Most finger prints can be removed with a neutral detergent or soap. When the stain is very evident use organic solvents such as alcohol or benzene with a sponge or soft rug. The surface shall be washed with a water rinse after cleaning.

(2) Stain from rain and dust

Wipe off with neutral detergent.

SCM

1. General

Stainless steel YUS220M, the surface skin material of the SCM panels resists rusting but is not rust free. Under some circumstances rust or staining may occur on the surface of the panel

The excellent corrosion resistance of stainless steel is derived from inactive fine oxide film formed on the stainless steel surface as a result of chemical reaction between chromium in the stainless steel and oxygen in the atmosphere. This inactive film protects the metal surface from various types of corrosion. When this film is damaged and the inactive film is breached rusting may occur. Once the inactive film reforms the corrosion resistance will be restored to its original level.

Staining and rusting of the stainless steel YUS220M is caused by the adhesion of various contaminants to the surface of the panel. Mild steel particles, aggressive gas and salt compounds will cause staining and rusting. When these components adhere to the stainless steel surface, they will react with the humidity and may breach the inactive oxide film layer that provides the stainless steel with its corrosion resistance. Cleaning and removal of the contaminants will allow the surface to oxidize and restore the inactive protective film.

2. Cleaning procedures

There are several causes of rust and stain. The cleaning method must be selected depending on the cause.

- a. Floating Metal Particles: If the rust is the result of metal particles adhered to the SCM surface and the rust is slight a mild detergent wash

followed by a water rinse should be effective. If the rust is more substantial and shows a distinct brown color a commercial cleaning solution for stainless steel or a 15% nitric acid solution can be used. If the rust is still remaining the surface may be polished with sandpaper or a stainless steel brush. After polishing clean with a commercial cleaning solution for stainless steel.

- b. Aggressive gases: In heavy industrial areas the air borne gasses may begin to rust the surface of the panels. The cleaning instructions in Group A should be followed and a scheduled cleaning should be done at least once per year.
- c. Salt Compounds: Follow the cleaning instructions in group a and schedule a periodic cleaning 3 to 4 times per year.
- d. Cleaning Chemicals: The solutions used to clean the Stainless Steel can themselves stain the metal's surface. A thorough water rinse is needed after cleaning.
- e. Finger prints: Follow the cleaning instructions for finger prints on TCM panels

Precautions on installation and fabrication

- (1) Generally speaking, if panel details are simplified, cleaning will be easier. Such projections as a cornice, soffit or sunshade shall be designed to avoid the flow and ponding of dirt carrying rainwater on the building's surface.
- (2) If welding and/or grinding work is being done in the area of installed and the possibility of sparks landing on the surface exists, the surface must be protected. Sparks from welding and/or grinding work will stick tightly on the surface and may not be removable.
- (3) The surface of the panel is protected with a protective film. The film should remain on the panel during fabrication and installation to prevent scratches and staining. Peel off the protective film as early as possible after completion.

General notes to cleaning procedures

- (1) Stains will be caused by various factors, and the staining condition will vary case by case. Therefore the cleaning method must be adapted to each situation. When a cleaning chemical will be used try a small inconspicuous test area prior to starting the overall cleaning.
- (2) Use a soft cloth or sponge for cleaning. Do not use abrasive cleaners, sandpaper, steel wool or cleaning tools made of metals. These might cause scratches on the titanium surface.
- (3) Clean not only the area of the stain but also the adjacent areas to avoid an uneven surface appearance.
- (4) After cleaning a thorough water rinse is necessary to remove the remaining chemicals.
- (5) Do not mix different cleaners.
- (6) Avoid cleaning under extreme temperatures. Heat may accelerate the chemical reaction and may evaporate water from solution. Cleaning under higher temperatures may result in streaking. Extremely low temperature, on the contrary, may give poor cleaning effects. Ideally, cleaning should be done on the shaded side of the building in a moderate temperature.